

Dual-Channel, 6 A Buck Regulator Delivers High Efficiency Compact Solutions

Zhongming Ye
Analog Devices, Inc.

System designers are asked to produce smaller, higher efficiency power supply solutions to meet the demands of power thirsty SoCs and FPGAs across all industries. The space available for the power supply footprint is critical in advanced electronics systems, as supplies must be placed near the SoC or its peripheral devices, such as DRAM or I/O devices. In a portable instrument, such as a handheld bar scanner, or medical data logger system, the space is even tighter.

The problem facing designers involves more than just finding a regulator that fits limited space. The requirements for compact solutions often run counter to other advanced electronics requirements: robust design, high efficiency, large conversion ratios, high power, a compact solution, and good thermal performance. Many of these requirements require trade-offs in other areas, which presents the designer with a difficult and time-consuming optimization problem. The **LTC3636** aims to ease the designer's task with a dual 6 A buck regulator that features very low standby current at shutdown, high efficiency in both full load and light load, and operation up to 4 MHz.

Compact Size with 4 MHz Switching Frequency

It is a nearly universal truth that the application space allotted for power supplies is barely enough. The solution volume and power density of a dc-to-dc converter is generally limited by its bulky magnetic components,

input/output capacitors, EMI filter size, and/or heatsink. In a step-down power converter, size and efficiency are often at odds: the size of the inductor and output capacitor can be significantly reduced by pushing the switching frequency higher, but high frequency operation leads to increased switching related losses in the inductor and the switches. This complicates thermal management in tight spaces.

The LTC3636 is a dual-channel, 6 A per output, high efficiency monolithic step-down regulator capable of operating from input supplies up to 20 V. The programmable switching frequency can be set as high as 4 MHz. The high switching frequency significantly reduces the size and value of the inductor and capacitor, but unlike many high frequency solutions, the LTC3636 also maintains high efficiency. Some very small footprint ferrite inductors with lower ac loss and dc loss can be used. The two channels operate 180° out-of-phase, with the interleaving of the switching pulses resulting in ripple cancellation, which in turn reduces the input capacitor values.

The dual buck converter in Figure 1 runs at 4 MHz, with very small inductors and capacitors. Efficiency and thermal performance are shown in Figure 2. The thermal image shows a less than 40°C temperature rise at room temperature where natural convection at $V_{IN} = 5 V$.

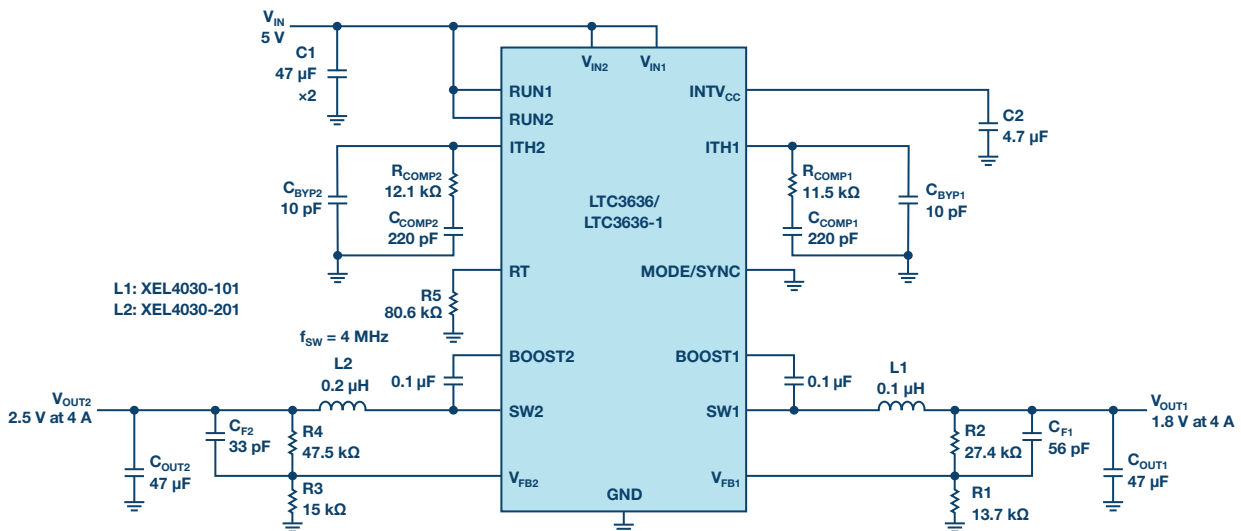

Figure 1. A 4 MHz dual buck regulator delivers a compact solution.

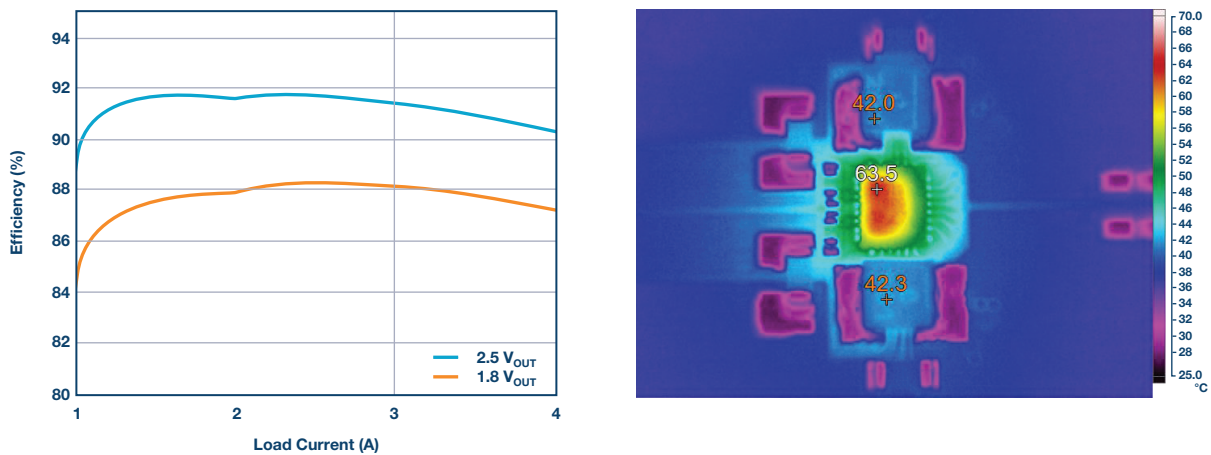

Figure 2. The efficiency curve (left) and thermal image (right). Condition: $V_{IN} = 5 V$, natural convection.

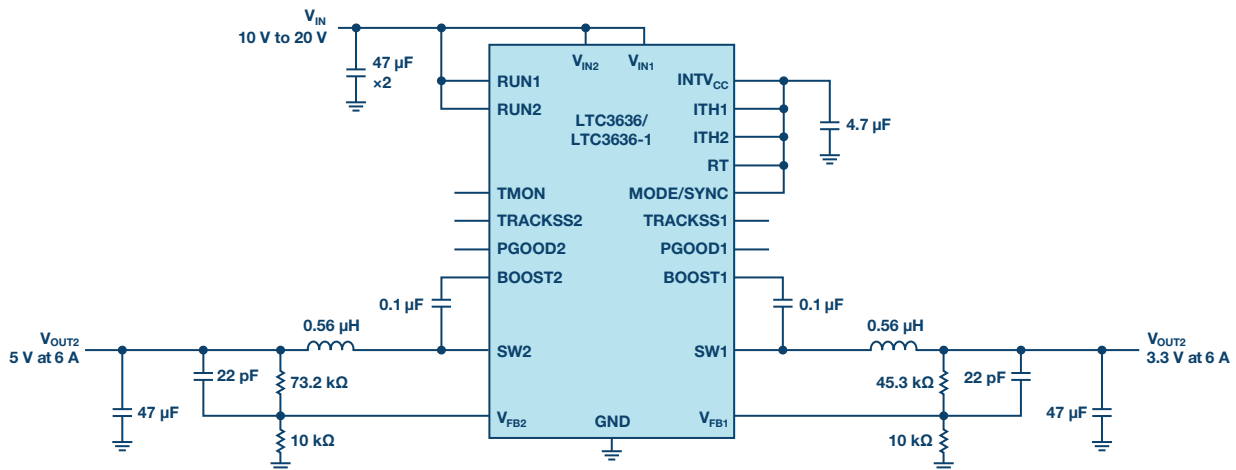

Figure 3. High efficiency dual buck regulator.

High Efficiency Power Conversion Over the Entire Load Range

High efficiency over the entire load range is critical for portable device and automotive applications. Under heavy load, the power loss should be small so that the circuit can run reliably. This can be achieved by optimizing the circuit design at heavy load with a combination of robust thermal protection and reliable thermal management through the TMON pin for thermal monitoring, where a heatsink or forced airflow might be unavailable.

High efficiency at a light load is also important for battery-powered systems to extend operation time between charges. Furthermore, low shut-down power consumption is critical to avoid drainage of a battery-powered system. A trade-off of efficiency at either heavy load or light load usually limits the performance of the overall solution.

The LTC3636 regulator features low quiescent current for high efficiency for output up to 5 V. The LT3636-1 version extends the V_{OUT} range to 12 V. The step-down regulator operates from an input voltage range of 3.1 V to 20 V while delivering up to 6 A of output current per channel. Figure 3 shows

a high efficiency solution while Figure 4 shows its measured efficiency remains high throughout the operating range.

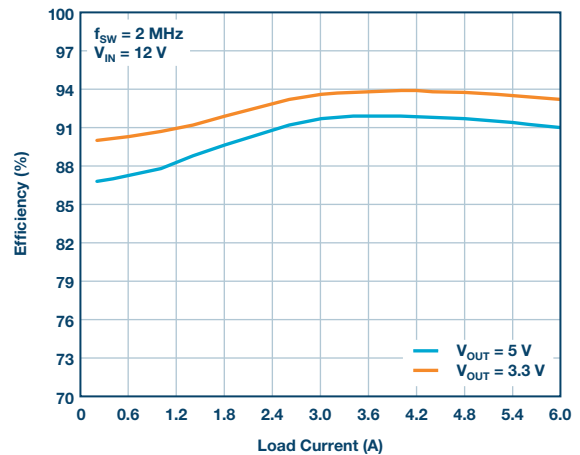
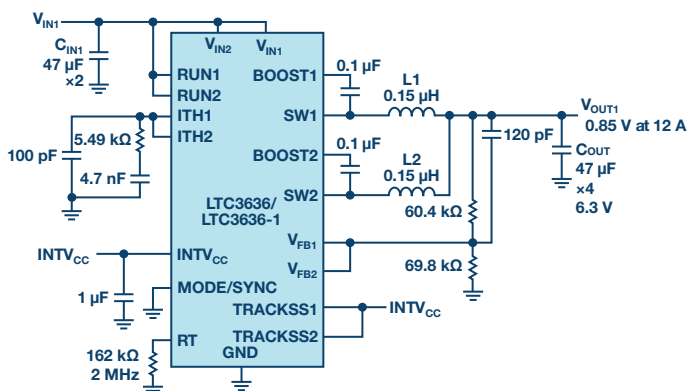

Figure 4. The efficiency curve for $V_{OUT} = 5 V$ and $3.3 V$.



L1, L2: 0.15 µF VISHAY IHP2525CZ

(a) Schematic of LTC3636

Figure 5. Schematic of a 12 A/0.85 V regulator and load transient.

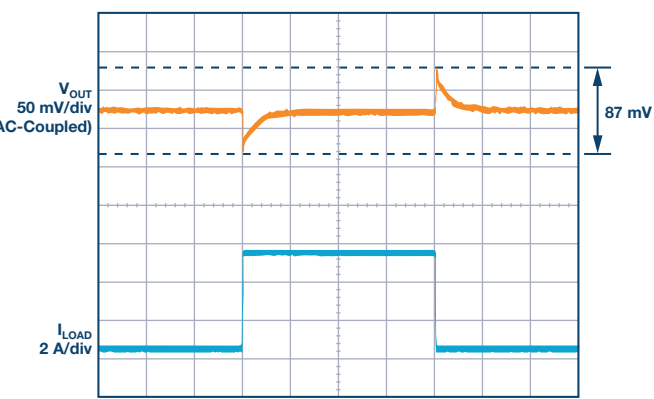
(b) Load Transient (2 A to 6 A, $V_{IN} = 3.3$ V)

Configurable for a 2-Phase Single Output up to 12 A

The proliferation of advanced SoC and FPGA electronic systems in automotive, transportation, and industry applications requires higher performance power supplies. Power budgets of these advanced SoCs continually rise and the solutions based on traditional PWM controllers and MOSFETs must give way to the monolithic regulators for more compact, higher current capability, and higher efficiency. LTC3636 is designed to meet these advanced SoC power budgets while fitting SoC size and thermal constraints. Figure 5a shows the schematic of the power supply with two channels in parallel to deliver current up to 12 A at 0.85 V. The peak efficiency of a 12 A output load is 87% when V_{IN} is 3.3 V. The load transient is shown in Figure 5b. In this design, the FB1 and FB2 pins are tied together, as are the RUN1 and RUN2 pins. The ITH1 and ITH2 pins are tied together with external compensation set to minimize current mismatch in steady state and transients as well.

Conclusion

The demand for more intelligence, automation, and sensing in industrial and automotive environments is resulting in a proliferation of electronic systems that require increasingly high performance power supplies. LTC3636 facilitates system design with two high efficiency rails that can each support up to 6 A, with very low standby current at shutdown. The LTC3636 is offered in a thermally enhanced, low profile 28-lead, 4 mm × 5 mm QFN package. The built-in overtemperature protection feature enhances reliability. A user selectable mode input is provided to allow the user to trade off

output ripple for light load efficiency. Burst Mode® operation provides the highest efficiency at light loads, while forced continuous operation provides the lowest output ripple.

About the Author

Zhongming Ye is a senior applications engineer for power products at Analog Devices in Milpitas, California. He has been working at Linear Technology (now part of Analog Devices) since 2009, where he provides application support on various products, including buck, boost, flyback, and forward converters. His interests in power management include high performance power converters and regulators of high efficiency, high power density, and low EMI for automotive, medical, and industrial applications. Prior to joining Linear Technology, he worked at Intersil for three years on PWM controllers for isolated power products. He obtained a Ph.D. degree in electrical engineering from Queen's University, Kingston, Canada. Zhongming was a senior member of the IEEE Power Electronics Society. He can be reached at zhongming.ye@analog.com.

Online Support Community



Engage with the Analog Devices technology experts in our online support community. Ask your tough design questions, browse FAQs, or join a conversation.

Visit ez.analog.com

Analog Devices, Inc. Worldwide Headquarters

Analog Devices, Inc.
One Technology Way
P.O. Box 9106
Norwood, MA 02062-9106
U.S.A.
Tel: 781.329.4700
(800.262.5643, U.S.A. only)
Fax: 781.461.3113

Analog Devices, Inc. Europe Headquarters

Analog Devices GmbH
Ott-Aicher-Str. 60-64
80807 München
Germany
Tel: 49.89.76903.0
Fax: 49.89.76903.157

Analog Devices, Inc. Japan Headquarters

Analog Devices, KK
New Pier Takeshiba
South Tower Building
1-16-1 Kaigan, Minato-ku,
Tokyo, 105-6891
Japan
Tel: 813.5402.8200
Fax: 813.5402.1064

Analog Devices, Inc. Asia Pacific Headquarters

Analog Devices
5F, Sandhill Plaza
2290 Zuchongzhi Road
Zhangjiang Hi-Tech Park
Pudong New District
Shanghai, China 201203
Tel: 86.21.2320.8000
Fax: 86.21.2320.8222

©2019 Analog Devices, Inc. All rights reserved. Trademarks and registered trademarks are the property of their respective owners. Ahead of What's Possible is a trademark of Analog Devices. DN21153-0-3/19

analog.com



AHEAD OF WHAT'S POSSIBLE™